

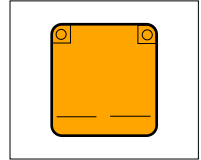

INFORMATION FOR FIRST AND SECOND RESPONDERS
EMERGENCY RESPONSE GUIDE



NIO ET5
ELECTRIC





Do not dispose of vehicle keys in household trash.
They contain materials that can be recycled.



Take the used battery to a recycling center or to your service center.

ONLINE USER MANUAL

This guide provides the basic operating instructions of NIO ET5. For owners who want insights and detailed information about the features and functions of the car, an in-depth online manual is available in our official website.

Contents

0. Rescue sheet	Page 02
1. Identification / recognition	Page 02
2. Immobilisation / stabilisation / lifting	Page 08
3. Disable direct hazards / safety regulations	Page 11
4. Access to the occupants	Page 13
5. Stored energy / liquids / gases / solids	Page 17
6. In case of fire	Page 19
7. In case of submersion	Page 20
8. Towing / transportation / storage	Page 20
9. Important additional information	Page 22
10. Explanation of pictograms used	Page 24

0. Rescue sheet

This Emergency Response Guide covers the NIO ET5 corresponding rescue sheet.

1. Identification / recognition



WARNING

Silent movement or instant restart capability exists until vehicle is fully shut down.

ET5 Information

Vehicle manufacturer	NIO
NIO hotline	Refer to the contact table
NIO official website	Refer to the contact table

You can find the vehicle certification label in the lower area of the right B-pillar.

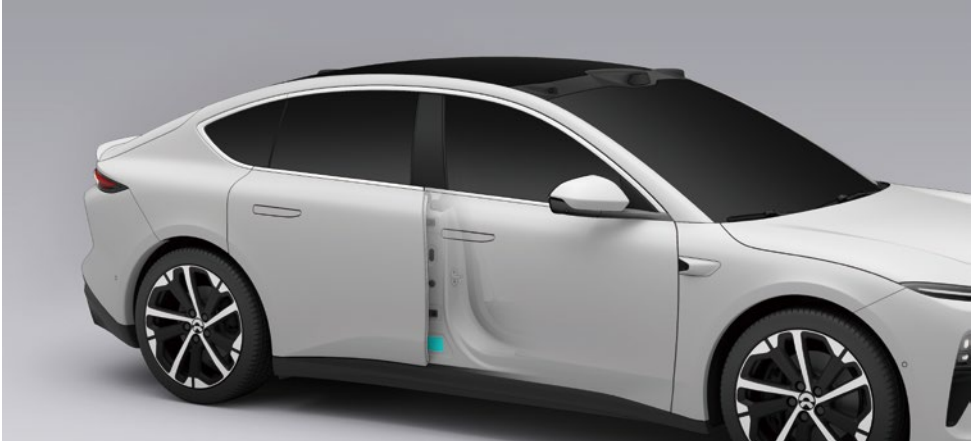

Vehicle brand label:

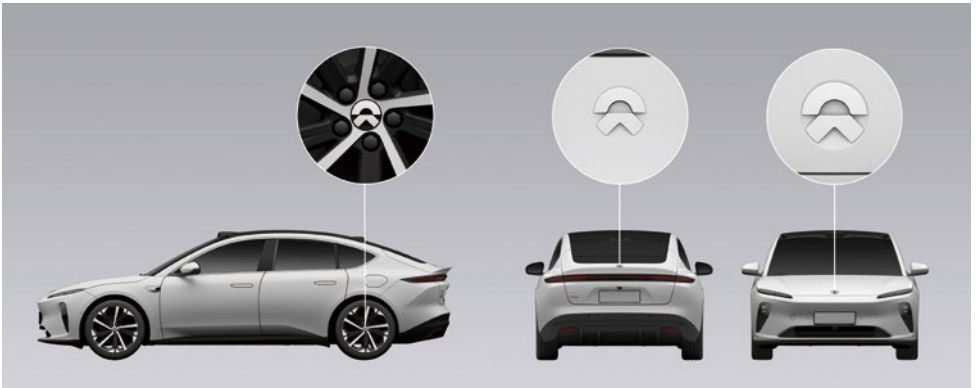

Instrument Cluster and Controls

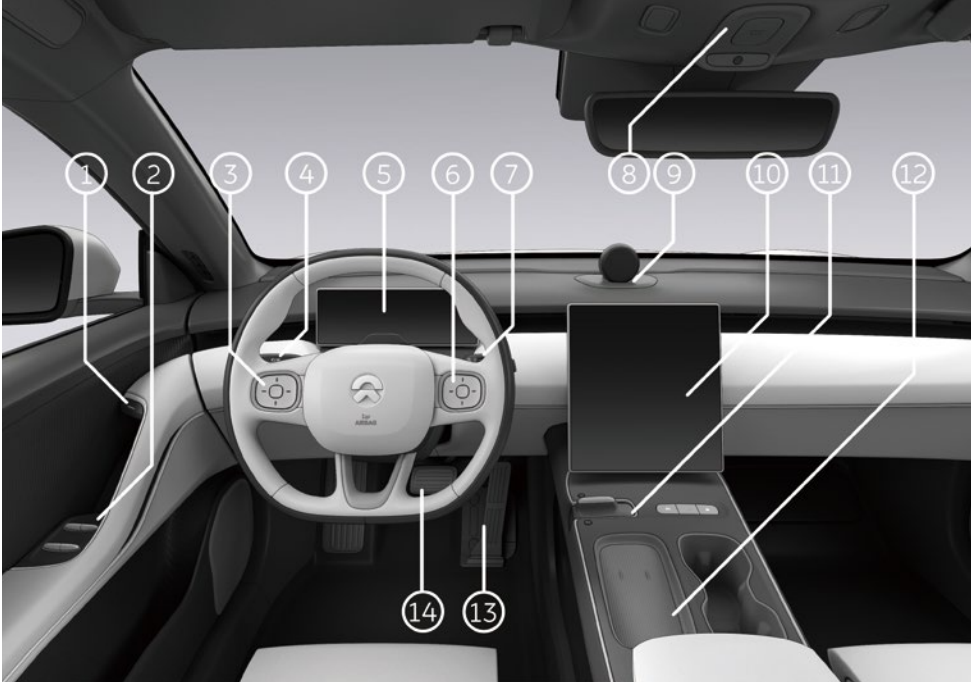







1. Electronic switches on interior door handles
2. Control panel for windows
3. Steering wheel buttons - left
4. Light control lever for turn signals and headlights
5. Digital instrument cluster
6. Steering wheel buttons - right
7. Wiper and washer control lever
8. Control panel for emergency calls and reading lights
9. Nomi*
10. Center display

11. Gear selector and center console control panel
12. Wireless charging pad
13. Accelerator pedal
14. Brake pedal

***NOTE**

The picture shows Nomi Mate.

Warning Sign Information

No.	Name	Warning Sign	Description
1	High voltage electricity warning sign		Danger! Do not touch high voltage components.
2	High voltage component warning sign 1		High voltage components. Risk of electric shock! Do not touch high voltage components without wearing protective equipment.
3	High voltage component warning sign 2		High voltage components. Risk of electric shock and burns! Do not touch high voltage components without wearing protective equipment.
4	High voltage battery pack warning sign		Cautions for using the high voltage battery pack.
5	High voltage cable warning sign		High voltage components are connected with orange high voltage harnesses. Do not touch high voltage components without wearing protective equipment.
6	Mutual compatibility identifiers used for charging the car		Mutual compatibility identifiers to guide you charging the car are found in the car's charging port. When selecting the charging gun, you must make sure the identifier on the charging gun equals one of the identifiers found in the car's charging port, either C, K or L. Voltage ranges related to those identifiers are as follows: C: AC ≤ 480V K: DC 50V to 500V L: DC 200V to 920V

Vehicle Identification Number (VIN)

The vehicle identification number (VIN) is stamped on the floor under the front passenger seat.

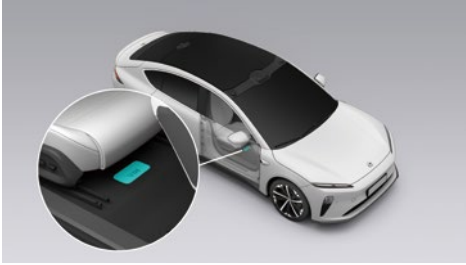

You can also find the VIN in the following locations:

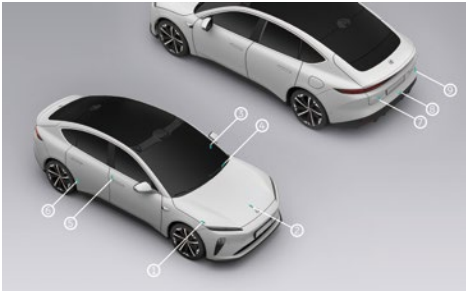

1. Underside of the hood
2. Upper area at the end of the front driving motor
3. Left side of the instrument panel beam
4. Lower-left area of the front windshield
5. Lower area of the right B-pillar
6. Lower area of the right rear door frame
7. Upper area at the end of the rear motor
8. Upper side of the rear floor
9. Right side of the trunk lid

You can also read the VIN from diagnostic instruments that pair with the vehicle (safety module diagnosis tool BD2):

1. Connect the diagnostic instrument to the diagnostic interface of the vehicle and turn it on.

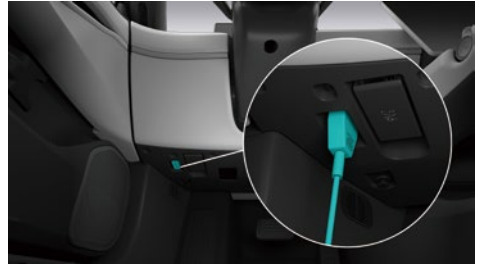

2. Start the diagnostic program and log in to the diagnostic instrument interface.
3. The diagnostic instrument automatically reads and displays the VIN on the interface of the diagnostic instrument.

There is a radio frequency identification device (RFID) at the front windshield of the vehicle. You can install your ETC device here.

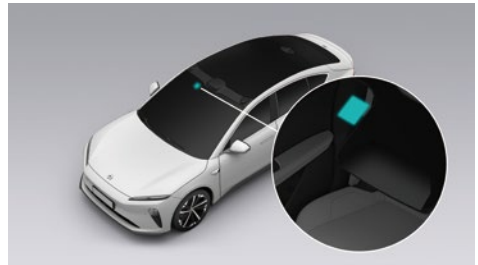

Driving Motor Identification Labels

The front driving motor identification label is located on the lower side of the motor.



The rear driving motor identification label is located on the lower left side of the motor.

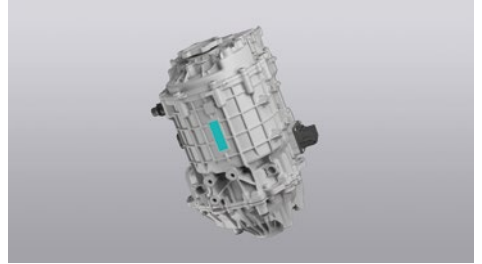

2. Immobilisation / stabilisation / lifting

Placing a Warning Triangle

In case of an emergency, please slowly and steadily drive the vehicle to a safe area, press the brake pedal to stop the vehicle, and shift into PARK. Then, you should turn on the hazard warning lights by pressing the button on the center console to warn other vehicles approaching from behind.



1. PARK button
2. Hazard warning light button

Open the cargo cover inside the trunk and take out the warning triangle and reflective safety vest from the emergency kit. You should put on the safety vest first, and then place the warning triangle at around 50 meters to 100 meters behind the vehicle (at least 150 meters behind the vehicle on the highway; add an additional 100 meters at night; 200 meters behind the vehicle in case of rain or fog).

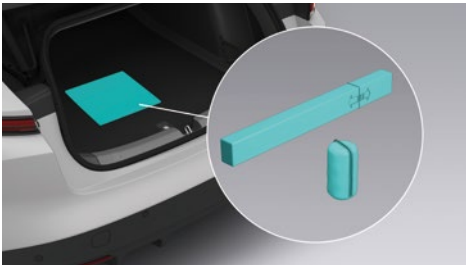

Instructions for setting up the warning triangle:

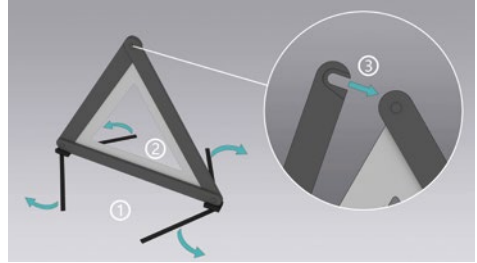

1. Deploy the bracket under the triangle.
2. Unfold the two sides of the triangle.
3. Fasten the buckle on top of the triangle.

Contacting NIO

In case of accidents such as collisions, floods, and battery fires, call the NIO hotline immediately after setting up the warning triangle, and the rescue team will provide assistance ASAP.



WARNING

In the event of a battery fire risk, the vehicle will automatically cut off power and the instrument cluster and center display will display a warning message. Make sure the surrounding area is safe and promptly leave the vehicle to call for help.

- When your vehicle is connected to the Internet, you can press the SOS button on the roof console (press and hold once or press twice) to call for rescue. You can cancel the call within 8 seconds. The backlight of the SOS button indicates the status of the emergency call: solid green indicates the emergency call function is normal; flashing green indicates an emergency call is in progress; solid red indicates the emergency call function failed and you must contact NIO immediately.



- In case your vehicle is not connected to the Internet, you can contact NIO via the NIO app.

NOTE

When the vehicle is connected to the Internet, it will automatically make an emergency call to protect your life if an accident occurs and the airbag inflates.

Tire Replacement

If a tire cannot be repaired with tire sealant due to a severe leak, park the vehicle safely on a flat and solid road as far away from traffic as possible and shift into PARK. Put on the reflective vest, set up the warning triangle, turn on the hazard warning lights, and contact NIO service center for tire replacement.



WARNING

- **When replacing a tire, the new tire must comply with the specifications of the original one. Using a tire with different specifications may affect the vehicle's handling and result in a loss of vehicle control.**
- **Never get underneath the vehicle when it is lifted on a jack as this may cause severe injury or even death.**
- **Do not lift the vehicle when people are inside.**
- **Do not place any object above or underneath the jack when it is lifting the vehicle.**

Follow the instructions to replace the tire:

1. Prepare a jack and a spare tire of the correct specifications.
2. Place a stopper in front of the tire diagonal to the flat tire to prevent the vehicle from slipping.

- Remove the lug bolt cap with the removal tool in the emergency kit, and then turn the lug wrench counterclockwise to loosen the lug bolts.





CAUTION

Tire rims have a special protective coating. When removing or installing lug nuts, tires or rims, take reasonable precautions to protect the rim's surface from accidental scratches caused by hard or sharp objects.

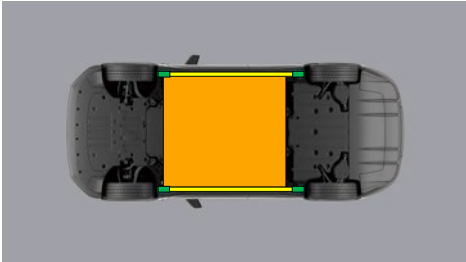
- Position the jack at the correct jacking point.



-  Appropriate lifting points
-  Appropriate points vehicle on side
-  High voltage battery



WARNING

Make sure the jack is positioned correctly under the jack point. Failure to do so may damage the vehicle, or the vehicle may slip off the jack and cause injury.

- Jack up the vehicle until the flat tire is sufficiently above the ground. When lifting the vehicle, check again to ensure the jack is properly positioned.

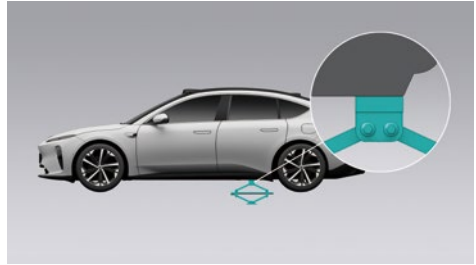

- Remove the lug bolts and change the flat tire. When mounting the new tire, ensure the lug bolts are aligned with the mounting holes and the metal surface of the rim is in proper contact with the mounting surface.
- After installing the lug bolts, use the jack to lower the vehicle to the ground. Tighten all the lug bolts clockwise with the lug wrench. Then, use a torque wrench to tighten the lug bolts to the specified torque.
- Check the tire pressure after replacement. If necessary, inflate the tires to the rated range, and then replace the tire valve cap.
- Properly stow all the tools, the jack, and the flat tire.

3. Disable direct hazards / safety regulations



WARNING

Be aware that not every high voltage component is labelled. Always wear the appropriate PPE (Rubber insulated gloves / insulated rubber shoes / tools with insulating protective cover / goggles). Do not attempt to open the high voltage battery.

Protective Equipment for Rescue Operations

The powertrain system is powered by the high voltage battery. Severe collisions and impacts may cause electrical leakage or electrolyte leakage. Therefore, rescue operations should be carried out by professionals who must wear personal protective equipment.



WARNING

Remove all metal objects (such as necklaces and watches) before carrying out any operation. Failure to do so may increase the risk of electric shock.

Electrical Protection

Wear the following protective equipment to avoid high voltage electric shocks:

- Rubber insulating gloves (over 500V insulation resistance)
- Goggles
- Rubber insulating boots
- Insulated tools

Chemical Protection

In case of electrolyte leakage, wear the following protective equipment to prevent skin and facial injuries:

- Protective face shield
- Chemical-resistant gloves

Cutting Off the High Voltage Circuit

To cut off the high voltage circuit, disconnect the emergency high voltage cutoff plug (located in the left area under the hood), and then disconnect the cable connected to the negative terminal of the 12V battery (located near the front windshield under the hood).

To cut off the high voltage circuit:

1. Pull the hood handle cover in the cabin twice to unlatch the hood.



2. Lift the hood.



3. Disconnect the emergency high voltage cutoff plug to cut off the high voltage circuit. Remove the plug and stow it properly.

There are 2 ways to cut off the high voltage circuit:

1. Main Disabling Method

In case of emergency, cut the harness with tool to shutdown the high voltage circuit.

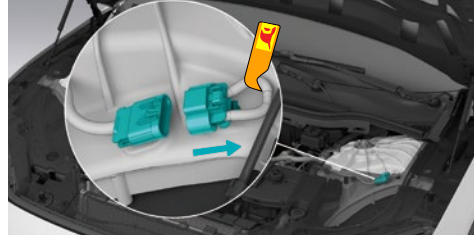
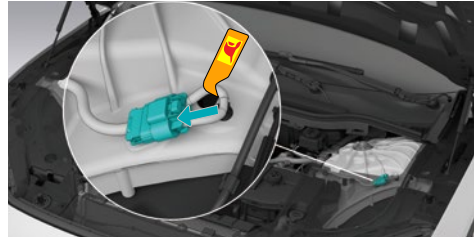
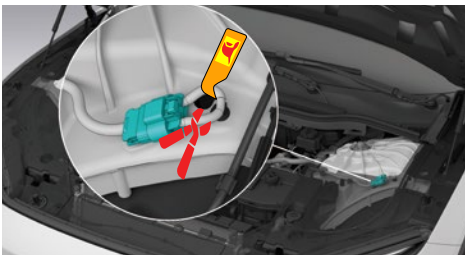
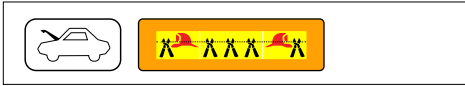

Access to 12V Battery

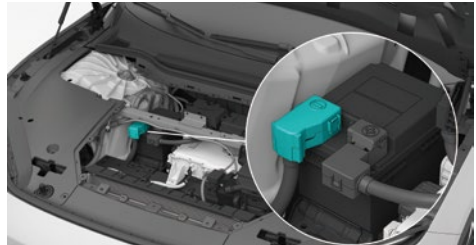
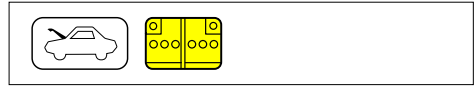

2. Alternative Method

In case of service operation or emergency, pull the connector position assurance out according to arrow direction, then disconnect the plug to cut off the high voltage circuit.



Airbags

The airbag system includes front airbags and side airbags. The front airbags include front head airbags that are located inside the trim flap of the steering wheel and at the instrument panel of the passenger side. The side airbags include front side airbags (located on the outside of the front seats and the inside of the driver's seat) and curtain airbags (located above the doors on both sides, in the roof area from A-pillar to C-pillar, containing the curtain cylinders). The presence of an airbag is indicated by the word "AIRBAG" in all places where the airbag is located.

4. Access to the occupants



Moving the Front Seats with Power

To adjust the seat position via a button

The position of the driver's seat can be adjusted 14 ways electrically. The lumbar support can be adjusted 4 ways electrically and the headrest can be adjusted 4 ways.



1. Length of seat cushion

Toggle the button back and forth to adjust the length of the seat cushion.

2. Inclination angle of seat

Turn this button to adjust the inclination angle of seat cushion.

3. Lateral position of the seat

Toggle this button back and forth to move the seat forward or backward.

Height of seat

Toggle the middle part of this button up or down to move the seat upward or downward.

4. Reclining of the backrest

Toggle the upper end of this button back and forth to adjust the reclining of the seat backrest.

5. Lumbar support adjustment

Press and hold the corresponding position button to adjust the lumbar support.



WARNING

- Before seat adjustment (forward and backward, height, backrest, etc.), make sure that there is sufficient safe space for the seat and children, occupants, and pets in the rear row to avoid squeezing or smacking into children, occupants, and pets in the rear row.
- Adjust the driver's seat position and headrest when the vehicle is in PARK. Seat position and other adjustments while driving may cause safety risks.
- During seat adjustment (forward and backward, height, backrest, etc.), avoid putting your hands or other parts of the body on the seat movement path to prevent pinching and colliding.
- Ensure that the seat is locked after position adjustment.

Controlling the movement of the driver's seat on the center display

You can control the movement of the driver's seat on the center display.



Opening the Hood with Power Tailgate

Opening and Closing the Tailgate by Pressing the Button

When you carry the smart key, lightly press the pressure plate on the handle of the tailgate to open the tailgate.

Your vehicle is equipped with a one-button tailgate closing feature.

Press the button on the tailgate to automatically close and lock the tailgate, and you will hear a “click” to confirm the closure.

Opening and Closing the Tailgate with the Center Display

Swipe right on the left edge of the center display to enter the Quick Settings page, then touch Rear Trunk to open the rear trunk.

Opening and Closing the Tailgate with the Smart Key

Opening the tailgate: press and hold the tailgate button on the smart key, and the tailgate will open automatically.

Closing the tailgate: press and hold the tailgate button on the smart key, and the tailgate will close automatically.

Door Handle

When the vehicle is fully unlocked, the outer door handles will pop up automatically, and you can open the door via sensing by gently touching the inside of the door handle.



You can open the door from inside by pressing the electronic switch on the corresponding inner door handles. Press once if the door is unlocked, or press twice if the door is locked, then the corresponding door will pop open.



Emergency Unlocking from the Outside

When the vehicle cannot be unlocked by conventional methods (such as a smart key fob, keyless entry, NIO app, or NFC), you can use the emergency key to unlock the driver's door.

CAUTION

Do not leave the emergency key in your vehicle. Please keep it safe in case of emergency.

To use the emergency key:

1. Pull out the metal key portion of the emergency key while toggling the switch on the emergency key.

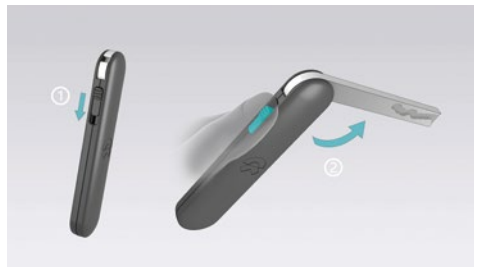

2. Push the front end of the exterior handle on the driver's door to extend the exterior door handle.

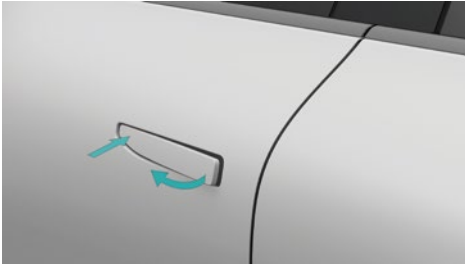

3. Pull the door handle and insert the emergency key into the keyhole. Rotate the key counterclockwise to unlock the driver's door.



4. To lock the driver's door, also press the front area of the exterior door handle, rotate the emergency key counterclockwise to unlock first, and then rotate clockwise to lock.

CAUTION

After using the emergency key to unlock the driver's door, if you need to use the smart key fob to lock the car door, you need to open and close the driver's door first to reset the lock cylinder. This prevents the driver's door from being unlocked.

Emergency Unlocking from the Inside

When the whole vehicle is locked, if the door needs to be opened in an emergency (for example, when the electronic switch on the door handle fails or the vehicle falls into the water), pull the mechanical switch on the interior door handle once to open the corresponding door.



CAUTION

- If the 12V battery is drained, you can only unlock the driver's door using the emergency key. Other doors can be unlocked and opened from the inside by pulling the mechanical switch on the corresponding interior door handle.
- When Child Locks for Doors are on, the rear doors cannot be opened from the inside and can only be opened from the outside when the vehicle is unlocked.

Emergency Trunklid Opening

To open the trunklid, lift the oval block above the lock buckle from the inside of the trunk, and then toggle the button in the hole with your finger.

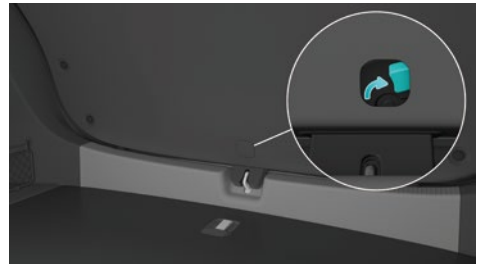

Windows



1. Laminated glass
2. Tempered glass

Vehicle Cutting













WARNING

When professional rescuers perform cutting operations, they must use appropriate tools such as a hydraulic cutter and wear appropriate personal protective equipment to avoid serious injury.

The vehicle pillars use aluminum castings to better protect the occupants in case of an impact. Please use proper tools to cut the pillars during a rescue. Do not cut any high temperature or high voltage areas on the vehicle, such as airbag components and high voltage components, as indicated by the red areas below.

5. Stored energy / liquids / gases / solids

	  	12V
	    	350V

Powertrain Information

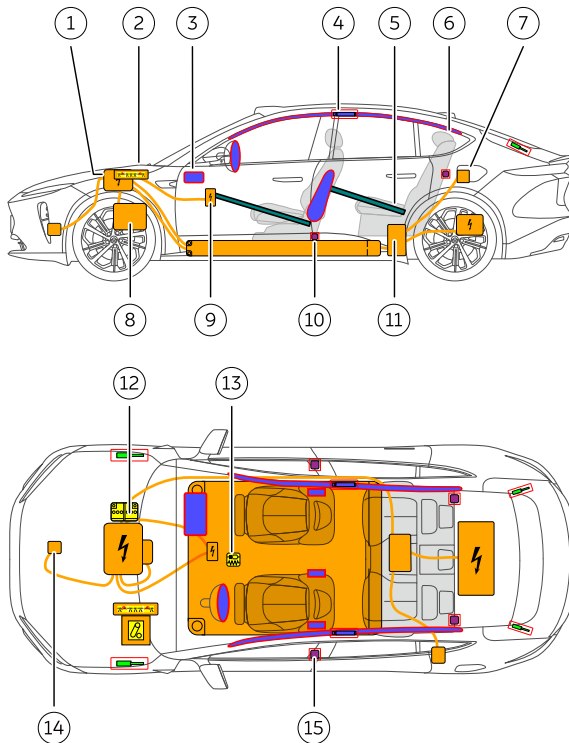

- | | |
|--|--|
| <ol style="list-style-type: none"> 1. High voltage DC converter integrated component 2. Emergency high voltage cutoff plug 3. Airbag 4. Curtain airbag cylinder 5. Structural reinforcement 6. Curtain airbags 7. Charge port | <ol style="list-style-type: none"> 8. Driving motor 9. High voltage heater for climate control 10. High voltage battery 11. High voltage integrated module 12. 12V battery 13. Airbag control unit 14. A/C compressor 15. Seat belt pretensioner |
|--|--|



High Voltage Battery

The vehicle is equipped with a 350V lithium-ion high voltage battery. Do not damage the battery when lifting from under the vehicle. When using rescue tools, please take special care to avoid breaking the underbody.



12V Battery

The 12V battery powers the Supplemental Restraint System, windows, locks, touchscreen, and vehicle lighting.

Rescue with Battery Leak



WARNING

- **Before servicing, removing and installing high voltage components, be sure to power off the vehicle and confirm that the emergency power-off switch and 12V power supply are disconnected. After the vehicle is powered off, let it sit for more than 5 minutes.**
- **No personnel without corresponding qualifications shall operate high voltage components. Operators must wear protective equipment such as insulating gloves that meet related requirements, and must not carry any metal objects.**



WARNING

If leakage from a high voltage battery is caused due to an impact, the rescue should be performed by professionals who must wear protective face shields and chemical-resistant gloves. Never make direct contact with the fluids.

When the high voltage battery leaks, it may generate heat or even cause a fire. Please cool down the high voltage battery first and then clean up the fluids:

- If the leak is not severe, use a liquid absorbing pad to clean up the fluids and then place the used pad in a closed container or use a professional incineration process to dispose of the fluids.
- If the leak is severe, dispose of the fluids following the disposal guidelines for hazardous chemical waste. Pour calcium gluconate solution over the leaked fluids and use gas collection and control devices to dispose of the leaked gases.

Driving Motor

The driving system powers the vehicle by converting the direct current from the high voltage battery into mechanical torque which is distributed to the four wheels. In addition, it can also recover kinetic energy to charge the high voltage battery when the vehicle is braking and operate to turn the drive shafts backward. The driving system consists of two driving motors. The front motor is mounted on the front subframe, and the rear motor is mounted on the rear subframe.

6. In case of fire



USE LARGE AMOUNTS OF WATER



BATTERY RE-IGNITION!



DO NOT SUBMERGE VEHICLE TO EXTINGUISH BATTERY

Rescuing the Vehicle on Fire



WARNING

- In the case of a vehicle fire, do not directly touch any part of the vehicle. All rescue operations should be performed by professionals who must wear appropriate personal protective equipment.
- The gas stored in the side curtain airbag cylinder and the high pressure air suspension tank may expand and explode under high temperatures. Please act with caution to avoid injury.

If the vehicle fire doesn't involve the high voltage battery, you can use the fire extinguisher to put out the fire.

If the vehicle fire is caused by the high voltage battery or the high voltage battery is overheated, deformed, cracked, or damaged in the fire, use a large amount of water or foam extinguishing agent mixed with water (F-500 EA is recommended) to cool down the high voltage battery. After the battery is completely cooled down (which may take up to 24 hours), monitor it for one more hour to ensure the battery does not heat up again. Then, drive the vehicle to an open and flat area and set up a 15-meter safety zone to keep people away from the vehicle.



WARNING

Be aware that a high voltage battery may re-ignite even after it is cooled down. Particular attention should be paid when transporting the battery.

7. In case of submersion

Rescuing the Vehicle in Water

CAUTION

When driving, do not submerge the vehicle in deep water for a long period of time. Otherwise, the vehicle's high voltage components may be damaged.

If the vehicle body and chassis are not damaged, there will not be any additional risks of electric shock. However, the rescue of a submerged vehicle should be carried out by professionals who must wear personal protective equipment. During rescue operations, first pull the vehicle out of the water and then cut off the high voltage circuit.

8. Towing / transportation / storage

STORE AT SAFE DISTANCE FROM OTHER VEHICLES!



BATTERY RE-IGNITION!



Towing the Vehicle after an Accident

CAUTION

This vehicle is not suitable for towing with wheels on the ground and do not tow the vehicle directly with tow chains.

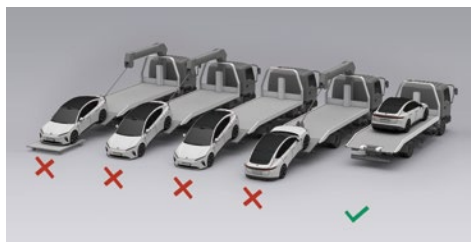

When necessary, transport the vehicle with a flatbed truck.

1. Take out the tow bar from the emergency kit in the trunk.

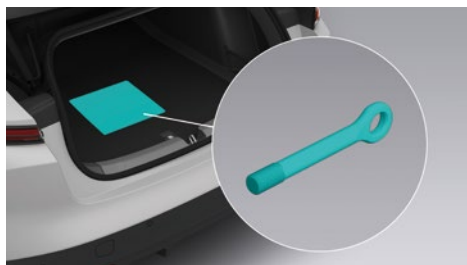

2. Release the tow bar cover by pressing firmly on the lower end of the cover (1). Fully insert the tow bar into the opening and rotate it until securely fastened (2). The tow bar at the rear is installed in the same way as the front.



3. Keep the vehicle in PARK, press the brake pedal, enter Settings from the control bar at the bottom of the center display, and tap **NEUTRAL**. The vehicle will release the parking brake and become towable. (Please use the wheel stopper accordingly to prevent sliding).
4. Before towing, power off the vehicle, turn on the hazard warning lights, and lock the whole vehicle after ensuring no occupant is in the vehicle.
5. Attach the tow chain to the tow bar and slowly tow the vehicle to the flatbed truck.
6. After pulling the vehicle onto the flatbed truck, use the wheel stopper and straps to secure the tires onto the truck.
7. Before transporting the vehicle, exit NEUTRAL on the center display to avoid damage to the vehicle during transportation.

CAUTION

- The vehicle can only be towed from the site when there are no safety risks in doing so. If the high voltage battery is deformed, leaking or emitting smoke, address the risk posed by the high voltage battery first.
- Try restarting the 12V battery if NEUTRAL cannot be turned on normally. If the parking brake cannot be released, use a tow dolly or a trailer to transport the vehicle a short distance.
- Do not slam on the brake pedal or accelerator pedal when exiting NEUTRAL on the center display.

9. Important additional information

Must read

Thank you for choosing NIO's ET5 model (hereinafter referred to as "ET5"). ET5 is a smart electric sedan. During your green journey with ET5, you will get a seamless and considerate user experience.

Before starting your journey with ET5, it is recommended that you read the User Manual from the center display to get all the information you need to use the vehicle. This Guide only covers the basic information of the vehicle, emergency response measures, and the corresponding rescue measures. For detailed information on all vehicle features, please refer to the User Manual from the center display. For information related to warranty and maintenance, please refer to the Warranty Manual from the center display.

The contents of this guide shall not be reproduced or modified in whole or in part without legal and valid authorization.

To avoid failure of the vehicle's function or personal injury, vehicle parts shall not be modified, adjusted or dismantled without legal and valid authorization.

The labels, logos and pictures used in this guide are for illustration purposes only, and the content is for reference only.

Please strictly follow the warning information in this guide to use your vehicle more safely.

Warning Information



WARNING

This content is closely related to personal safety and must be complied. Failure to comply may lead to personal injury or serious accident.

CAUTION

This content gives you tips on how to avoid possible vehicle damage or property damage.















NOTE

This content gives you suggestions for better use of your vehicle.

If you have any questions about this guide, please call the NIO hotline, or log on to the NIO official website to obtain the latest version of the ET5 User Manual.

If you need assistance in an emergency, please call the NIO hotline.

10. Explanation of pictograms used

	Warning high voltage		Flammable
	Caution		Hazardous to the human health
	Air-conditioning component		Acute toxicity
	Electric vehicle		Corrosives
	Bonnet		Gases under pressure
	Boot		Explosive
	Use thermal Infrared camera		Use water to extinguish the fire